

USING TORSIONAL VIBRATIONS FOR DETERMINING MOMENT OF INERTIA OF A DISC

Tatiana E. Kuznetsova^{*}, Natalia L. Urvantseva

Department of Mathematics and Natural Sciences,
St. Petersburg State Polytechnical University, Grazhdanskii 28,
195251, St. Petersburg, Russia

*e-mail: tanuhakuznetsova@gmail.com

Abstract. In this contribution we report on the execution of a real laboratory work on the determination of moment of inertia for a circular disc in order to check Steiner theorem using the experimental setup of the company PHYWE. The results obtained are subjected to mathematical treatment of the basis of mathematical statistics. Analyzing the results, the students have possibility to compare them with the theoretical ones. Experiment planning, modeling and estimating the quality of models developed during the fulfillment of a real laboratory work helps to form research skills of the students.

1. Introduction

Nowadays college teachers are tasked not only with developing student professional knowledge and skills, but also with their professional competence, enabling them to address practical tasks relevant to their professional activities. Research skills are fundamental to professionalism of college graduates. Development of college student's research skills emerges as an important issue. Laboratory experiments are of a significant and integral part of educational process in physics. Taking classes in physical laboratories, students learn to use measuring devices, to gain experimental work experience. Laboratory work is often student's first real research.

In recent years the presence of a large number of computer programs and software has contributed to the creation of virtual labs. Setting Virtual Labs allows one to create a laboratory complex at minimal cost. However, it should be noted that for future engineers skills to work with experimental equipment and real instruments are very important. The absence of real instruments significantly affects the necessary professional skills, so even the best computer experience can not completely replace the real one.

In this article we consider the execution of a real laboratory work on the determination of moment of inertia for a circular disc in order to check Steiner theorem using the experimental setup of the company «PHYWE» [1]. The laboratory is incorporated in the Department of mathematics and natural sciences at the Institute of International Education Programs of Saint Petersburg Polytechnical University. Students who take course 'Laboratory experiments' are foreign students from near and far abroad. Laboratory experiments for foreign students have a peculiarity because many of them have never worked in a physics laboratory. Besides the first-year students have problems with Russian language [2]. We cannot expect that foreign students can master the same literature as Russian students. Therefore, the theoretical material in the description of a laboratory work should be sufficient and be correlated with the content of the lectures on the topic. The language of descriptions is

extremely simple and adapted to an understanding for the foreign students. Description of a laboratory work also contains a thesaurus of necessary physical terms that the students are able to use for admission to and during protection of the laboratory work done.

2. Experimental

The laboratory experiments "The moment of inertia of a disk. Steiner's theorem" helps students to understand and to learn the dynamics laws of rotation of a solid. The experimental setup is shown in Fig 1. The students experimentally determine the period of vibration of the horizontal circular disc 5, which performs torsional vibrations around various parallel axes going through various holes 8. For this purpose they measure the angular restoring moment with the spring balance which acts in a hole of the disc.

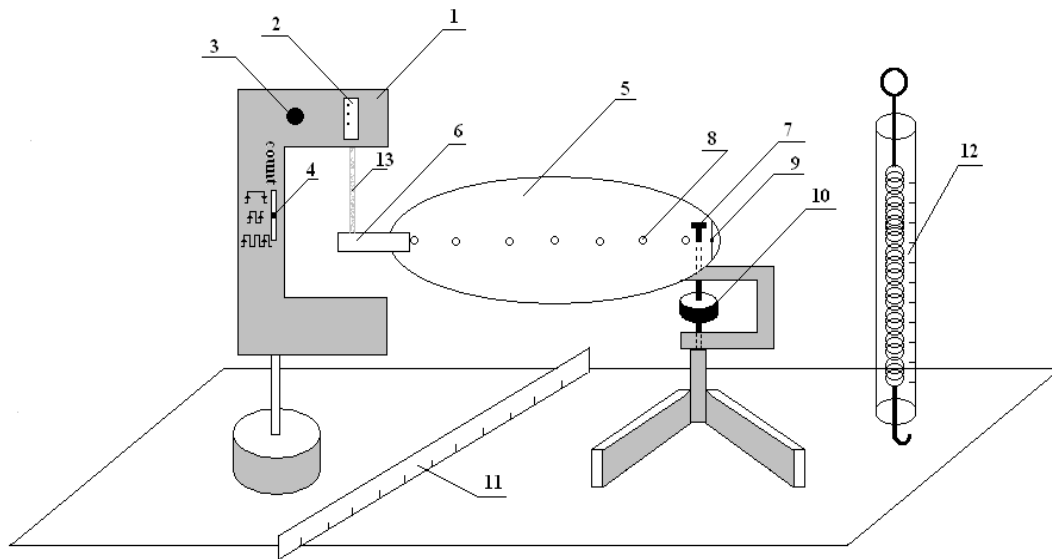

Fig. 1. Experimental setup.

In Fig. 1 the disc 5 rotates around the fixed vertical axis 7. A coil spring, connected with the axis, exert the restoring torque M_z that is proportional to the angular displacement φ from an equilibrium position, i.e.

$$M_z = -D\varphi, \quad (1)$$

where D is an angular restoring constant (torsion constant). Using the rotation analog of Newton second law for a solid body:

$$I_z \frac{d^2\varphi}{dt^2} = -D\varphi \quad (2)$$

we can find the equation of motion:

$$\frac{d^2\varphi}{dt^2} + \omega^2\varphi = 0. \quad (3)$$

The form of this equation is exactly the same as that of the equation for simple harmonic motion. The angular frequency ω is given by

$$\omega = \sqrt{\frac{D}{I_z}}, \quad (4)$$

where I_z is the moment of inertia of the disc around an axis. Accordingly, the frequency and the period of torsional vibrations are

$$f = \frac{1}{2\pi} \sqrt{\frac{D}{I_z}}, \quad T = 2\pi \sqrt{\frac{I_z}{D}}. \quad (5)$$

Equation (5) is the basis of a common method for experimental determination of the inertia moment of a body of any shape. The disc vibrates around the axis z with a period T . Defining the angular restoring constant D and the vibration period T of a torsion pendulum, one can find the inertia moment I_z of the disc

$$I_z = \frac{T^2 D}{4\pi}. \quad (6)$$

The experimental part of the work begins with the definition of the torque M_z of a coil spring as a function of the twist angle φ of the disc. Knowing this relationship, one can find the angular restoring constant D . Dynamometer 12 (Roman balance) is used for determining the restoring moment M_z acting on the spring. The restoring moment is measured for the following twist angles: $\pi/2, \pi, 3\pi/2, 2\pi, 5\pi/2, 3\pi$. For each angle the restoring force is measured several times. The measurement results are entered in Table 1. Then one finds the average for torque \bar{M} at a given angle φ .

Table 1.

No.	Twist angle of the disc	F						\bar{F}
		F_1	F_2			F_{n-1}	F_n	
n	φ	M_1	M_2			M_{n-1}	M_n	\bar{M}

Traditionally, the descriptions of laboratory works contain the accurate indication of how many times one should measure the value of a physical quantity. And students usually do not realize why the physical quantity must be measured five times, and sometimes ten times. In this work, students are encouraged to design an experiment and to estimate the number of necessary measurements. It is known that the result of multiple measurements contains random $(\Delta M)_{rand}$ and instrumental σ_{dev} errors. The total error can be found using the law of addition of errors:

$$\Delta M = \sqrt{(\Delta M_{rand})^2 + (\sigma_{dev})^2}. \quad (6)$$

It is named as a mean-square error.

Measurements of the restoring force and moment include uncontrolled processes (human factor), so the force and the torque behave themselves as random variables. Random error (let us refer it to the measured value M) is equal to:

$$(\Delta M)_{rand} = t(\alpha, n) \sigma_{\bar{M}}, \quad (7)$$

where α is a confidence limit (in laboratory studies one usually uses $\alpha = 0.68$), $t(\alpha, n)$ is the Student coefficient, which depends on the confidence probability α and the number of trials n , $\sigma_{\bar{M}}$ is the mean-square error (or standard deviation) of the mean value of

the measured quantity M .

With an increasing number of experiments, a variance

$$\sigma_M^2 = \frac{1}{n-1} \sum_{i=1}^n (M_i - \bar{M})^2 \quad (8)$$

(and respectively a single error $\sigma_M = \sqrt{\sigma_M^2}$) ceases to depend on n and becomes constant. If all the quantities have one and the same variance, i.e. $\sigma_{M_i}^2 = \sigma^2$, then according to the theorem of variance addition, the variance of their arithmetic mean equals $\sigma_{\bar{M}}^2 = \sigma^2 / n$. Therefore $\sigma_{\bar{M}} = \sigma / \sqrt{n}$ and hence it is possible to decrease $(\Delta M)_{rand}$ in \sqrt{n} times. Consequently the random error of average value $(\Delta M)_{rand}$ may be reduced with increasing number of measurements. Reducing the random error is reasonable until the total error is determined only by the error of measuring instruments. This condition can be considered fulfilled if $\Delta M_{rand} \leq \sigma_{instr} / 10$. In practice [3-5], one uses the less stringent condition $\Delta M_{rand} \leq \sigma_{instr} / 2$.

The instrumental error is defined by an instrument used. In our case, the instrument accuracy depends on the accuracy of measuring the arm of force with the help of a ruler and the force using a dynamometer. An instrumental error does not depend on the number of measurements. In our case, the instrument error is completely determined by the error of measuring the arm of force and the force:

$$\delta = \frac{\Delta M_{instr}}{M} = \sqrt{\left(\frac{\Delta l}{l}\right)^2 + \left(\frac{\Delta F}{F}\right)^2}. \quad (9)$$

Example. Consider the following example. Let the number of measurements is $n = 5$, the standard deviation of an individual measurement $\sigma_{M,n} = 0.0014 N \cdot m$ and $\sigma_{instr} = 0.0014 N \cdot m$.

To determine the required number of measurements N , which is necessary for fulfilling the condition $\Delta M_{rand,n} \leq \sigma_{instr} / 2$, write down the following inequality

$$(\Delta M)_{rand,n} = \frac{\sigma_{M,n} t(\alpha, n)}{\sqrt{N}} \leq \frac{\sigma_{instr}}{2}. \quad (10)$$

From this it follows that

$$N = \left[\frac{2 \sigma_{M,n} t(\alpha, n)}{\sigma_{instr}} \right]^2. \quad (11)$$

In our case, it must be $N = 6$, i.e. one must measure the restoring force six times (three times when the disk rotates clockwise and three times when the disk rotates counter-clockwise). For a given angle φ , it is necessary to find the average torque \bar{M} and to obtain six pairs of numbers (φ_1, \bar{M}_1) , (φ_2, \bar{M}_2) , ... (φ_6, \bar{M}_6) . The experimental results are given in Table 2.

Table 2.

φ_i, rad	1.57	3.14	4.71	6.28	7.85	9.42
$\bar{M}_i, N \cdot m$	0.0266	0.05315	0.0994	0.1351	0.1666	0.19915

For the results obtained, it is necessary to build an adequate model, and to assess the quality of the model developed. In order to construct the regression curves and determine their

parameters, it is worthwhile to use existing programs, but for the first time it would be more useful if the students perform all the steps of constructing the model "by hand". Based on the theoretical considerations, in our case on Hooke's law, we can assume that the relationship $\overline{M}(\varphi)$ is linear. Putting points $(\varphi_i, \overline{M}_i)$ on a plane (Fig. 2), we see that they are located close to a straight line, i.e. their coordinates are approximately satisfying a linear relation:

$$M_i = a \varphi_i + b, \quad (12)$$

where a and b are constants.

Let us find these parameters in such a manner that the straight line $M = a \varphi + b$ passes closest to the experimental points. In other words, the deviation of the experimental points from linearity must be minimal. To do so, one may use the method of least squares. In this case the measure of deviation is the sum of squared differences

$$S = \sum_{i=1}^n (M_i - b - a \varphi_i)^2, \quad (13)$$

which must be minimal. Considering the quantity S as a function of a and b , write the extremum conditions

$$\frac{\partial S}{\partial a} = 0, \quad \frac{\partial S}{\partial b} = 0. \quad (14)$$

Differentiating, we obtain

$$\frac{\partial S}{\partial a} = \sum (M_i - b - a \varphi_i)(-\varphi_i) = 0,$$

$$\frac{\partial S}{\partial b} = \sum (M_i - b - a \varphi_i)(-1) = 0.$$

Introduce the notations:

$$S_1 = \sum \varphi_i, \quad S_2 = \sum \varphi_i^2, \quad V_1 = \sum M_i, \quad V_2 = \sum \varphi_i M_i,$$

and rewrite the extremum condition in the new notations. Then we obtain the system of equations for determining parameters a and b .

$$\left. \begin{array}{l} S_1 a + n b = V_1 \\ S_2 a + S_1 b = V_2 \end{array} \right\}. \quad (15)$$

The determinant of this system is equal to $D = S_1^2 - n S_2$, so the estimates of a and b are

$$\tilde{a} = \frac{n V_2 - S_1 V_1}{D}, \quad \tilde{b} = \frac{S_2 V_1 - S_1 V_2}{D}. \quad (16)$$

Using the experimental data, we obtain

$$\tilde{a} \cong 0.0222 N \cdot m / rad, \quad \tilde{b} \cong -0.0078 N \cdot m, \quad \tilde{M} = 0.022 \varphi - 0.0078,$$

where \tilde{M} is the unbiased estimate of the regression function (12).

The estimates of the variance of these coefficients can be found with the help of the following formulas [5]:

$$\sigma_a^2 = \frac{\sigma^2 n}{D}, \quad \sigma_b^2 = \frac{\sigma^2 S_2}{D}, \quad \sigma_M^2 = \frac{\sigma^2 (-S_2 + 2S_1 \varphi - n \varphi^2)}{D}. \quad (17)$$

Substitution of the experimental data gives the mean standard deviations of \tilde{a} and \tilde{b} :
 $\sigma_{\tilde{a}} = 0.0013 N \cdot m / rad$, $\sigma_{\tilde{b}} = 0.0026 N \cdot m$.

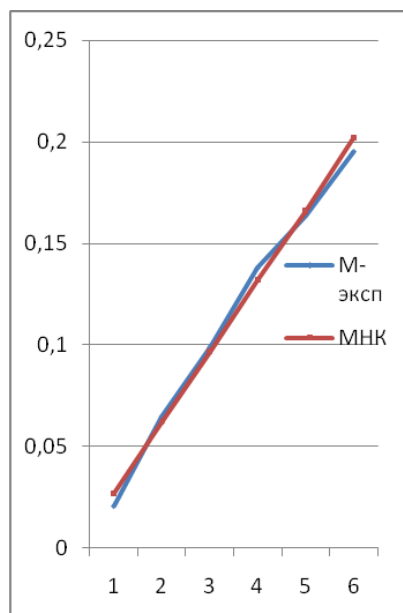

Fig. 2. Experimental broken line ‘M’ and regression line ‘MНК’.

The values obtained allow us to determine the number of meaningful decimal places in the values of a and b . The variance estimates give the confidence interval for a , b , and M . Having evaluated the elasticity modulus D , the students are measuring the vibration period of the pendulum at different positions of the pendulum axis. (Fig. 1). The measurement are done using the device comprising the light source 1, which overlaps the radiation screen 6, and the counter of the number of vibrations with the digital display 2. To determine the moment of inertia, a regression analysis may also be used.

Analyzing the results, the students have possibility to compare them with the estimated value of the moment of inertia by means of the formula $I_z = mR^2 / 2$, as the disk mass m and its radius R are known. In the case of significant differences of the results obtained with the calculated values, it is necessary to analyze what experimental factors could cause it. Experiment planning, modeling and estimating the quality of models developed during the fulfillment of a real laboratory work helps to form research skills of students.

References

- [1] PHYWE system GmbH&Co.KG, D-37070 Göttingen.
- [2] T.E. Kuznetsova, E.A. Nikitina, A.B. Stepanova, K.M. Chuvaeva, In: *Proceedings of the VII International Conference “International Cooperation in Engineering Education”* (July 2012, St. Petersburg, Russia).
- [3] B.D. Agapiey, V.N. Belov, F.P. Kesamanly, V.V. Kozlovskii, S.I. Markov, *Treatment of Experimental Data* (St. Petersburg, 2002) (in Russian).
- [4] V.A. Yavorskii, *Planning of Scientific Experiment and Treatment of Experimental Data* (MFTI, Moscow, 2006) (in Russian).
- [5] A.N. Zaidel, *Measurement Errors of Physical Quantities* (Lan’, St. Petersburg, 2005) (in Russian).